

Device description

Actuating Drive M453/M1203

with straight-way/three-way valve RV/RH/RVW/RHW125..200

**Three-way valve with actuating drive RVW125/150M453
Three-way valve with actuating drive RVW200M1203**

PN16

Application

Grey cast iron three-way valves RVW125..200 with actuating drives M453/M1203 serve to sensitively regulate amounts of liquids. The actuating drive is controlled via a three-state contact Open/Stop/Close.

Types

Grey cast iron three-way valve RVW.. with actuating drive M453/M1203 for water of up to 120°C, 16 bars, as well as for hot water of up to 200°C, 13 bars

	DN	PN	kvs	Δp (bars)	Floating time (s)	Weight
RVW125M453	125	16	250	2.5	125	78 kg
RVW150M453	150	16	400	1.5	125	109 kg
RVW200M1203	200	16	630	2.5	165	280 kg

Technical data – Valves RVW125..RVW200

Nominal width	DN125..200
Pressure stage	PN 16
Connection	Flange acc. to DIN 2533
Characteristic	equal percentage
Actuating stroke	RVW125/150: 60 mm, RVW200: 80 mm
Leak rate	acc. to EN 1349, Leakage Class IV
Medium temperature	0..200°C

Housing	Grey cast iron	GG-25 0.6025
Seat ring	CrNi-Steel	1.4021
Cone	CrNi-Steel	1.4057
Valve spindle	CrNi-Steel	1.4057
Spindle sealing	PTFE lip rings	

Valve principle

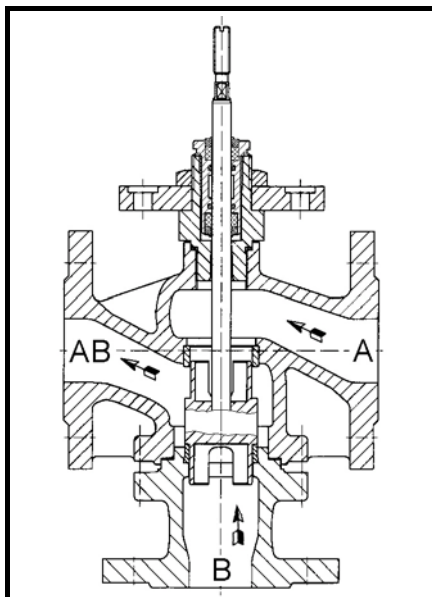

Technical data with the connection of the actuating drives can be found on pages 3 to 6.



III. RVW150M453

Actuating Drive M453/M1203

with straight-way/three-way valve RV/RH/RVW/RHW125..200

Device description

PN16 Three-way valve with actuating drive RVW125/150M453
 Three-way valve with actuating drive RVW200M1203

Dimensions

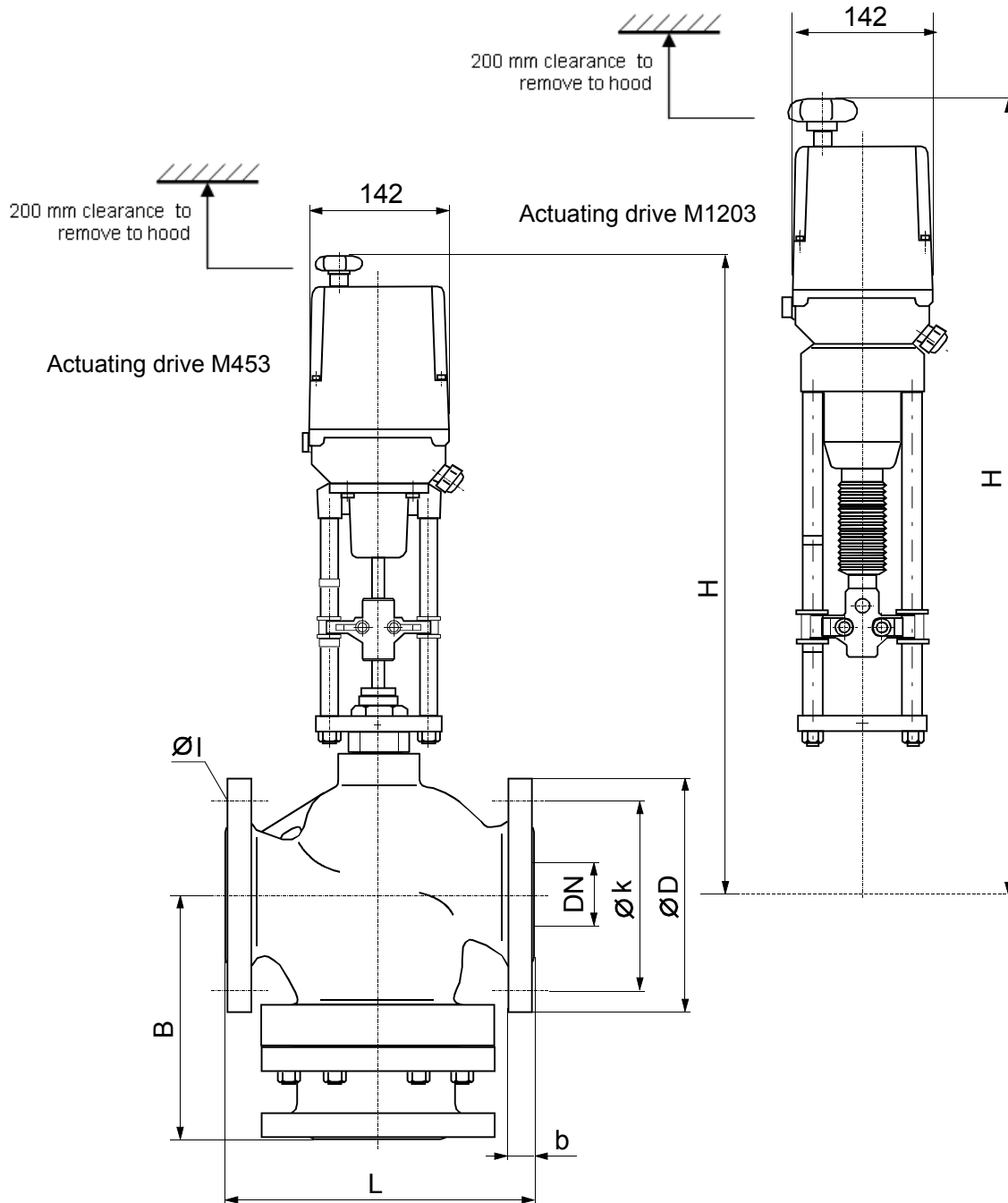

DN	L	b	Ø D	Ø k	Ø I	H
125	400	26	250	210	8 x Ø 18	ca. 730 (Actuating drive M453)
150	480	26	285	240	8 x Ø 22	ca. 750 (Actuating drive M453)
200	600	30	340	295	12 x Ø 22	ca. 985 (Actuating drive M1203)

Dimensions L to H in mm